

## YANMAR MARINE DIESEL ENGINES SY-D36

PART NO : SY-D36

PART NO : SY-D27



PART NO : SY-D40



- **Reliable**

Boat owners relate to the advantages of a diesel: lower chance of electrical fault, better fuel economy and a long, reliable work filled life.

- **Long hours**

Useful for trolling, working nets or fish farming, the diesel can't be matched in low speed operation. The combustion chamber and new cooling system allows for hours of idling.

- **Cool**

The thermostat cools the engine in response to how hard it is working by changing the temperature of the water.

- **Superior**

Special cast iron cylinder liners are bonded onto the one piece aluminium block. Minature fuel injection pumps are combined with nozzles to form "unit injectors" which are super compact

### Technical Details

#### Engine and Block

- One piece aluminium block.
- Cast iron cylinder bonded to the block.
- With a five coat painting process, the engine is protected both inside and out.

#### Fuel System

- Precise fuel metering with quick response.

#### Cooling System

- Seawater thermostat

#### Exhaust System

- Minature injection pump and reduced smoke.

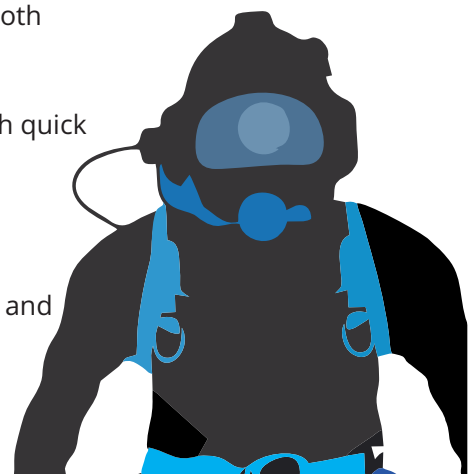

## YANMAR MARINE DIESEL ENGINES SY-D36



Model	D36
Configuration	4-cycle, vertical, water cooled diesel engine
Number of cylinders	3
Bore and stroke mm	82 x 70 (3.23 x 2.76)
Displacement cc (cu. in.)	1019 (68)
Maximum output hp(kW) /rpm at crankshaft	36hp/4500rpm (26.5kW/4500rpm)
Combustion system	Direct injection
Starting system	Electric with emergency rope start
Cooling system	Direct seawater cooling by rubber impeller pump
Lubrication system	Forced lubrication with trochoid pump
Generator	AC dynamo built in flywheel
<b>Drive device</b>	
Clutch type	Dog type clutch
Reduction ratio Ahead/ Astern	1.846/1.846
Direction of rotation	Clockwise viewed from propeller
Lubrication system	Oil bath
Tilt up system	AX-E manual AX-EP hydraulic
Control device	
Engine speed control	Remote control
Clutch control	Remote control
Steering	Remote control
<b>Transom installation</b>	
Fuel oil	Diesel fuel with kerosene (Add lube oil, 30:1)
<b>Fuel oil capacity l(cu.in)</b>	24 (1465)
Lube oil	Engine: SAE 15W40, API CD/ Drive: SAE 80W90, API Gear oil #90
<b>Dry weight</b>	
L-type	116kgs (256lbs) 120kgs (265lbs)
LL-type	117kgs (258lbs) 121kgs (267lbs)
UL-type	118kgs (260lbs) 122kgs (269lbs)

**YANMAR MARINE DIESEL ENGINES SY-D36**

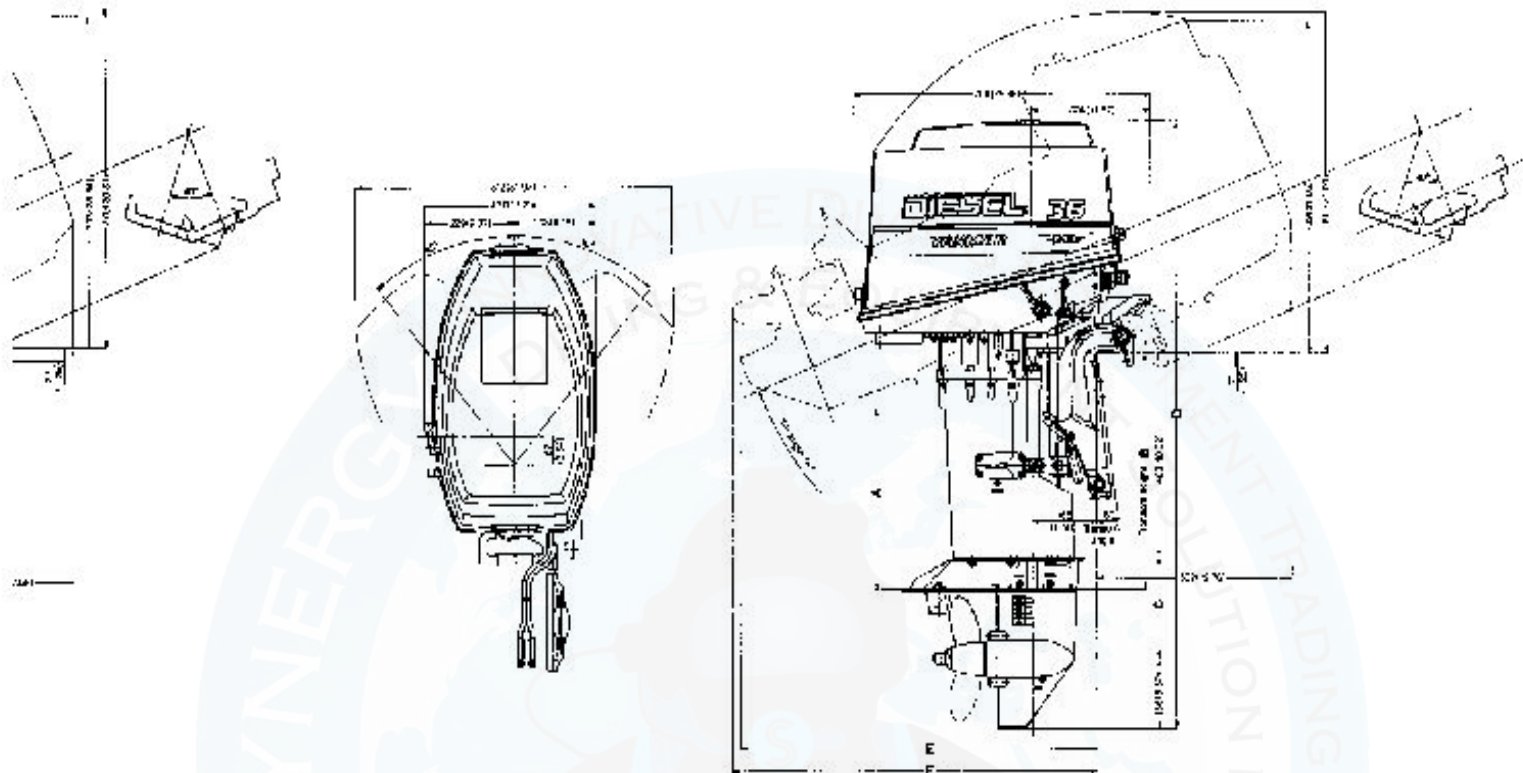

	<b>A</b>	<b>B</b>	<b>C</b>	<b>D</b>	<b>E</b>	<b>F</b>
<b>L-type</b>	<b>402</b> (15.83)	<b>560</b> (22.05)	<b>239</b> (9.41)	<b>1380</b> (54.33)	<b>889</b> (35.00)	<b>892</b> (35.12)
<b>LL-type</b>	<b>442</b> (17.40)	<b>623</b> (24.53)	<b>302</b> (11.89)	<b>1443</b> (56.81)	<b>947</b> (37.28)	<b>952</b> (37.48)
<b>UL-type</b>	<b>482</b> (18.98)	<b>685</b> (26.97)	<b>364</b> (14.33)	<b>1505</b> (59.25)	<b>1005</b> (39.57)	<b>1009</b> (39.72)

## YANMAR MARINE DIESEL ENGINES SY-D36

# ACCESSORIES

	D27	D36
Transom length, L-type, 560mm	●	●
Transom length, LL-type, 623mm	●	●
Transom length, UL-type, 685mm	●	●
Charging dynamo, 12V-10A	●	●
Charging dynamo, 12V-20A	▲	▲
Bolts and nuts for outboard motor clamp	●	●
Remote control bracket for engine speed & clutch shift control	●	●
Remote control bracket for steering control	●	●
Bar handle control	▲	▲
Hydraulic tilt switch	-	●
Spare parts kit	▲	▲
Half tilt device	▲	▲
Special overhauling tool kit	▲	▲
F.O tank (24ℓ), hose 2m & connect parts	●	●
Tool kit	●	●
Operation manual	●	●
Propeller clamp kit	●	●
Propeller, 3-10.5 x 9	▲	-
Propeller, 3-10.5 x 9.5	▲	-
Propeller, 3-10.5 x 10	▲	-
Propeller, 3-10.5 x 10.5	▲	-
Propeller, 3-10.5 x 11	▲	-
Propeller, 3-10.5 x 11.5	▲	-
Propeller, 3-10.5 x 12	▲	-
Propeller, 3-10.5 x 12.5	▲	-
Propeller, 3-10.5 x 13	▲	-
Propeller, 3-11.5 x 9	-	▲
Propeller, 3-11.5 x 10	-	▲
Propeller, 3-11.5 x 10.5	-	▲
Propeller, 3-11.5 x 11	-	▲
Propeller, 3-11.5 x 11.5	-	▲
Propeller, 3-11.5 x 12	-	▲
Propeller, 3-11.5 x 12.5	-	▲
Propeller, 3-11.5 x 13	-	▲
Propeller, 3-11.5 x 14	-	▲
Propeller, 3-11.5 x 15	-	▲
*Remote control Assy, S-type (Standard) (included: Starter switch, Manual engine stop, L.O alarm lamp)	●	●
*Remote control Assy, A-type (included: Starter switch, Manual engine stop, Type 2 panel, Wireharness 5m, 2m, Alarm panel)	▲	▲
*Remote control Assy, B-type (included: Engine stop solenoid, Wireharness 2m, Extension wireharness 5m)	▲	▲
*Remote control Assy, C-type (included: Remote control head NA12, Engine stop solenoid, Wireharness 2m, Extension wireharness 5m)	▲	▲
*Remote control Assy, D-type (included: Remote control head NA12, Engine stop solenoid, Wireharness 5m, 2m, Alarm panel with Tachometer, Hour meter)	▲	▲

\*Refer to detail table ● : Standard ▲ : Option - : Not available

# REMOTE CONTROL ASSY

Assy Name	S	A	B	C	D
Engine Remote control head	-	-	▲	▲	
Speed Governor	▲	▲	▲	▲	▲
Shift	-	-	-	-	-
Steering	-	-	-	-	-
Starting Device	●	▲	-	-	-
Engine Stopping Device	-	-	▲	▲	▲
Kill-SW.	-	-	-	▲	▲
Lube oil Alarm lamp	●	-	-	-	-
Tachometer sensor	-	-	-	-	●
Tilt SW.	-	-	-	▲	▲
Instrument panel	-	▲	-	-	-
Alarm panel	-	▲	-	-	▲
Wire-harness	-	▲	-	-	-

● : Equipped on engine. ▲ : In packing - : Not included

# Contact us



29th Street, Amman Road, Behind Al Huraiz Est. For Industry,  
Al Qusais, Industrial Area - 1,  
Dubai, United Arab Emirates



Tel : 009714 2580533 



Fax : 042516664 



UAE : 00971505648178 



UK : 00447951966260 



Website : [www.synergyequipment.com](http://www.synergyequipment.com)



Email : [ram@synergyequipment.com](mailto:ram@synergyequipment.com)



For Sale : [info@synergyequipment.com](mailto:info@synergyequipment.com)

