

SYNERGY DIESEL ENGINE DRIVEN HYDRAULIC POWER PACK



This operation manual contains information that is vital to the successful installation, operation & maintenance of the equipment. Before attempting to use the power pack, carefully read the entire operating Manual. Special attention should be paid to the section "Safety Precautions"

Model :	SVOE-HPPK-52HP-2P
Frame size :	2000 mm x 1000mm x 1650mm (L x B x H)
Gross weight :	1200kg
Tank capacity :	220 Ltrs.
Maximum flow :	37.4 LPM per Pump at 1500 RPM X 2 (Max 45LPMx2)
Operating Pressure :	140.Bar with both pumps running/Loaded
Pump Max. pressure. :	210 Bar.
Pump. :	Triple Tandem Pump
Hydraulic oil :	ISO GRADE-68 above 30°C- ISO GRADE 46- 7°to30°C



SYNERGY DIESEL ENGINE DRIVEN HYDRAULIC POWER PACK

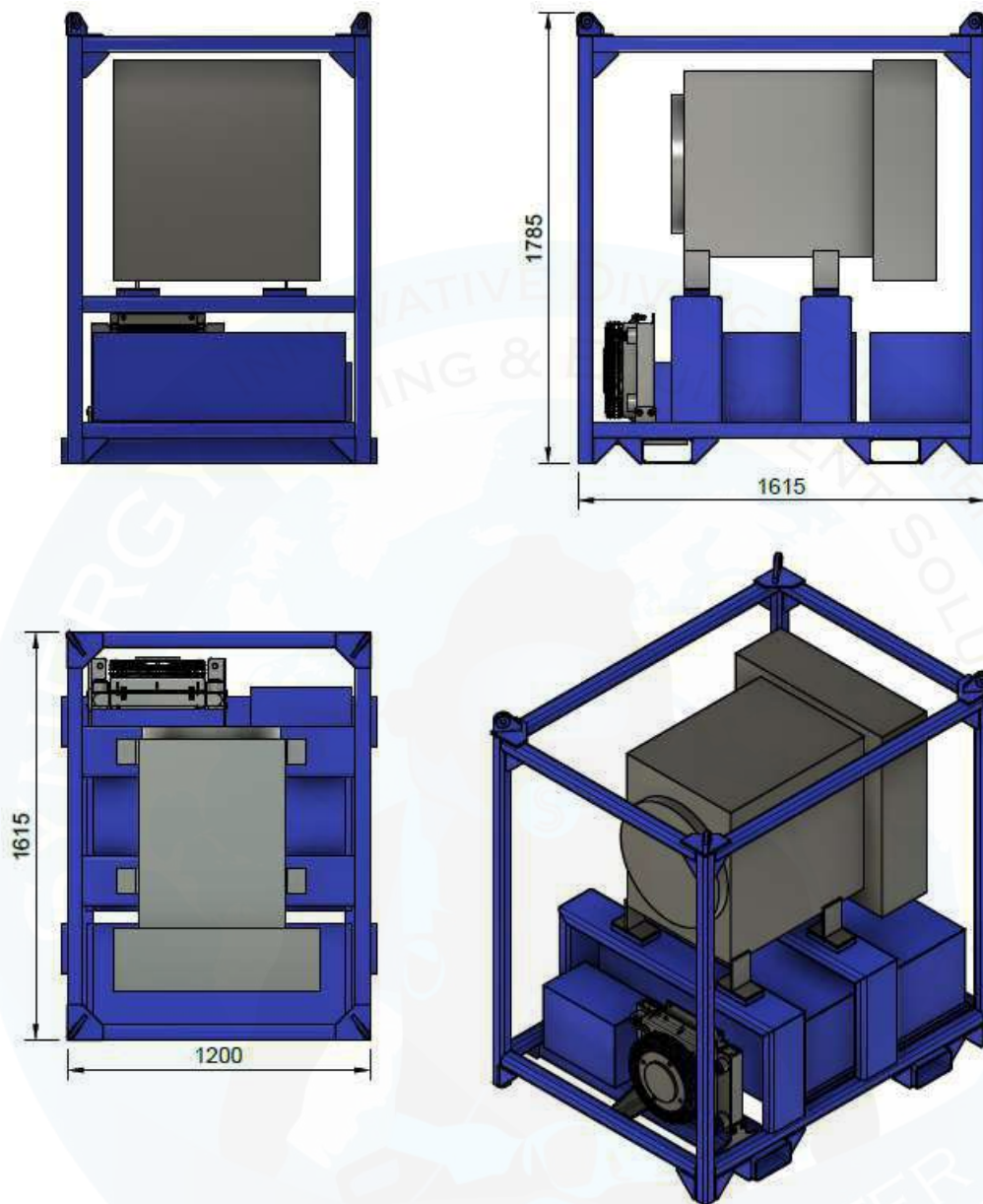

General Information

Description

The Diesel Hydraulic Power Unit (DHPU) is an open frame type power unit designed to provide hydraulic power to under water tools. The unit is self contained.

The DHPU , powered by 4 cylinder Volvo Eicher (VECV) diesel engine. Attached to the engine is a two section Tandem Vane pump. Both sections provide Hydraulic fluid power for the one or two hydraulic Tools .

- Instrument panel with engine speed, oil temperature and oil pressure.
- Electric start
- Safety package with over speed shutdown, Emergency Stop and spark arrestor
- Shutdowns for low oil pressure, high oil temperature high coolant temperature.
- 100 liters diesel reservoir with level gauge, drain port and filler breathe
- System relief valve set at 2000 PSI/140 Bar. Can be adjusted according to tool requirement
- 220 hydraulic reservoir with level gauge, cleanout cover, suction strainer with , return filter, drain port with ball valve and filler breather
- The power pack is Housed in a steel frame with 4 x lifting Pad eyes

SYNERGY DIESEL ENGINE DRIVEN HYDRAULIC POWER PACK



Location of the Unit

Remember the following points when positioning the power unit for installation.

- The physical space required for the unit is detailed in the general specifications page. Consideration should also be given for access around the power unit for startup procedures and maintenance activities.
- Also, take into account the location of the power unit to keep it as close as possible to the equipment in order to reduce pressure losses in the line. Pressure losses from long hose lengths can reduce the system performance and generate significant heat.
- Ensure the exhaust and intake air paths are unobstructed. The engine exhaust should be directed towards a well ventilated area and pointed away from any operator positions.
- If located near an operator, then proper safety equipment such as ear protection should be worn by all personnel near the unit.
- The diesel power unit incorporates several safety devices. However, this combustion engine driven power unit is neither designed nor certified as an explosion proof system.

SYNERGY DIESEL ENGINE DRIVEN HYDRAULIC POWER PACK

Engine System Inspection

Examine the following areas on the diesel engine after the unit is in its final position. Do not inspect the engine while it is running. Review the included engine manuals for detailed instruction.

- With the power unit on level terrain, check the engine Oil level using the dipstick. The level should be between the minimum and maximum marks. Add motor oil to the inlet if the level is below the minimum mark. Refer to the engine manual for the type of motor oil required. As a general rule, use SAE 10W-30 motor oil for average ambient operating temperatures below 45°F (7°C), SAE 15W-30 for 45° to 85°F (7° to 30°C) operation and SAE 15W-40 for operation above 85°F (30°C).
- It will be necessary to purge the fuel system from air that may have been introduced during transportation, during repair/maintenance work or if the system ran until the fuel tank was empty. If air bubbles are in the fuel system, the power unit will have difficulty running or may not run at all. See the figure below for the location of the priming pump. Reference the engine manual for procedures to bleed the fuel system. Check the fuel level in the diesel tank. Add fluid through the fluid fill port. Commercial grade diesel fuel should be used. Refer to the engine manual for details on summer or winter grades of diesel
- Refer to the engine manual for service and maintenance schedules for the motor fuel filter and oil filter. These filters ensure the purity of the fuel and oil reaching the engine systems. If necessary, then replace the filters per the instructions in the manual prior to operation.
- Remove all debris and coarse dust from the collector prior to starting the engine. The previous photo shows the location of the dust collector. Review the service and maintenance section of the engine manual for further instructions.
- Check the oil condition and air cleaner. If the oil needs replacement, then follow the instructions for cleaning and replacement in the engine manual.

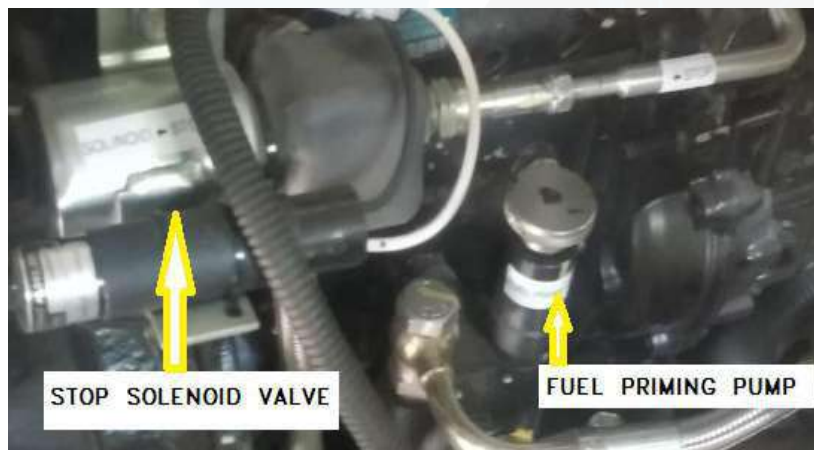

ENGINE CONTROL PANEL

SYNERGY DIESEL ENGINE DRIVEN HYDRAULIC POWER PACK

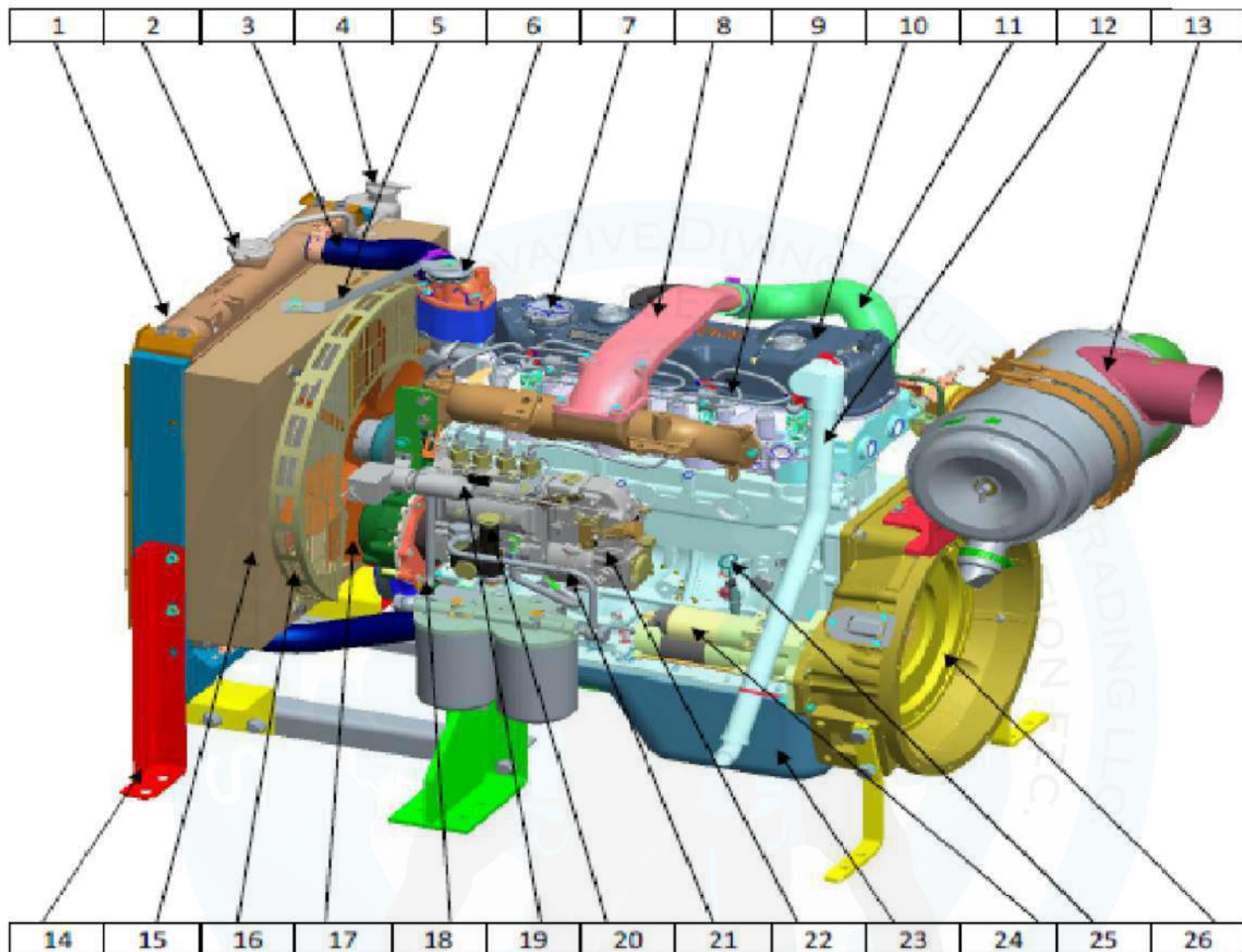

1	Radiator	14	Strip-Support radiator
2	Radiator Cap	15	Shroud Radiator
3	Hose- Radiator In	16	Guard Fan Radiator
4	Tank Condenser	17	Fan Cooling Radiator
5	Bracket – Radiator Support	18	Pipe- Fuel filter to Fuel injection pump
6	Cushion-Radiator Support Bracket	19	Stop Solenoid
7	Cap Oil Filler	20	Feed pump
8	Pipe- Turbo to Intake Manifold	21	Pipe fuel- Feed Pump to fuel filter
9	High Pressure Pipe	22	Fuel injection Pump
10	Rocker Cover	23	Oil Sump
11	Hose- Turbo out	24	Starter Motor
12	Hose Breather	25	Dip Stick
13	Air cleaner Assembly	26	Flywheel

SYNERGY DIESEL ENGINE DRIVEN HYDRAULIC POWER PACK

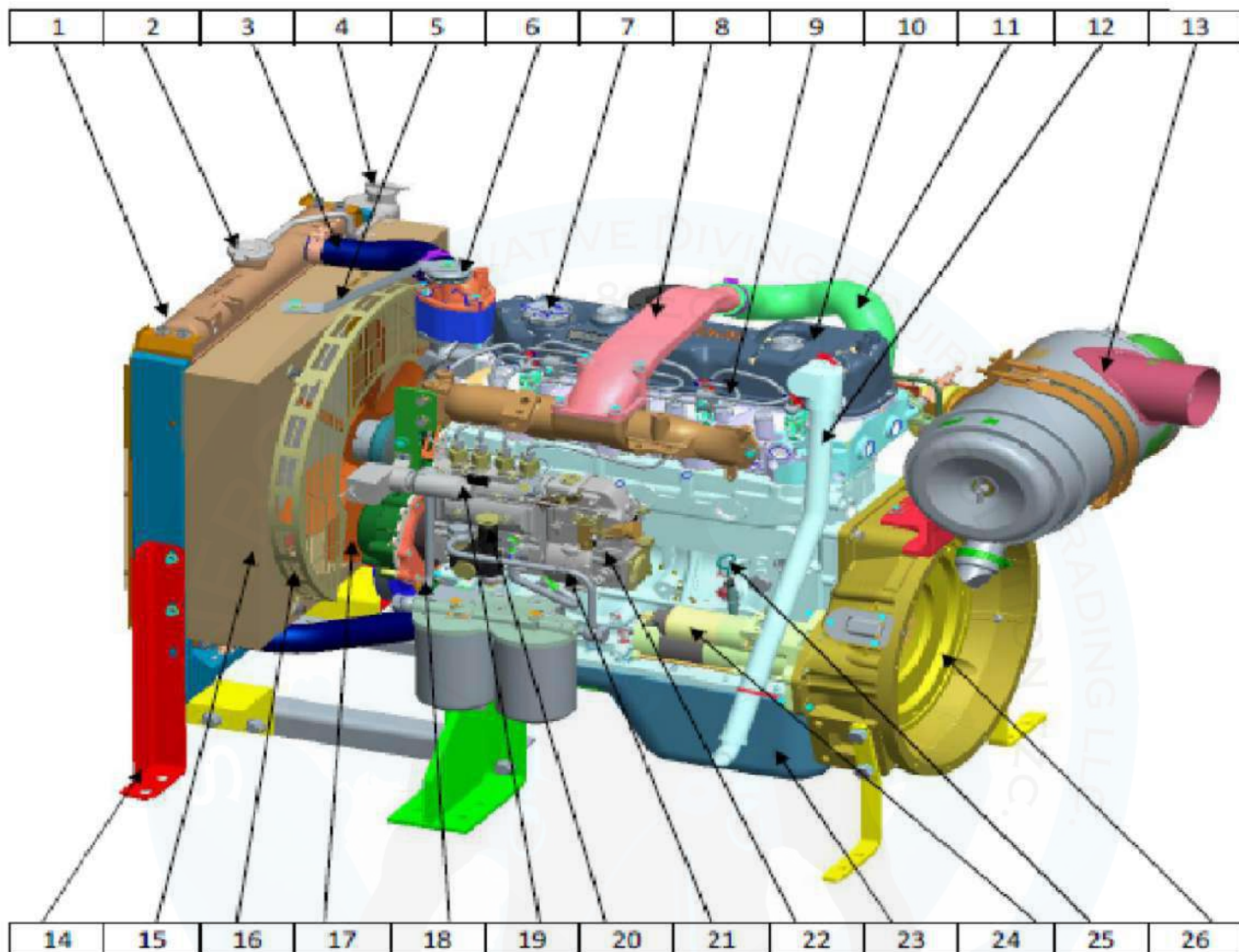

1	Radiator	14	Strip-Support radiator
2	Radiator Cap	15	Shroud Radiator
3	Hose- Radiator In	16	Guard Fan Radiator
4	Tank Condenser	17	Fan Cooling Radiator
5	Bracket – Radiator Support	18	Pipe- Fuel filter to Fuel injection pump
6	Cushion-Radiator Support Bracket	19	Stop Solenoid
7	Cap Oil Filler	20	Feed pump
8	Pipe- Turbo to Intake Manifold	21	Pipe fuel- Feed Pump to fuel filter
9	High Pressure Pipe	22	Fuel injection Pump
10	Rocker Cover	23	Oil Sump
11	Hose- Turbo out	24	Starter Motor
12	Hose Breather	25	Dip Stick
13	Air cleaner Assembly	26	Flywheel

SYNERGY DIESEL ENGINE DRIVEN HYDRAULIC POWER PACK

Hydraulic System Inspection

The following steps review the hydraulic system to ensure it is ready for operation.

- Check the fluid level of the hydraulic tank. For operation, the fluid level should be seen in the level gauge as detailed in the following photo. If the level is low, then add hydraulic fluid through the filler/breather until the level reaches the top of the level gauge. When the filler/breather cap is removed, take care to avoid the passage of contaminants into the hydraulic reservoir. A premium hydraulic fluid is recommended for use ISO grade 32 for average ambient operating temperatures below 45°F (7°C), ISO grade 46 for 45° to 85°F (7° to 30°C) operation and ISO grade 68 for operation above 85°F (30°C).
- Verify the interconnect hoses or piping is adequate for the maximum flow generated from the power unit. Undersized lines will lead to a buildup of heat and a decrease in system performance. A hose set can be purchased separately with connectors matching the power unit installed.
- For quick installation and to reduce spills on connection, the power must be fitted with quick disconnects. Never connect or disconnect the lines when the power unit is running. Before connecting the quick disconnects to the unit, ensure that the faces of the connectors are free from debris. Remove any particles with a lint free rag. Dust plugs and caps are included with the connectors to prevent contamination during transportation and storage. Connect the pressure and return lines using the quick disconnects. The following photo shows the location of the pressure and return quick disconnects.

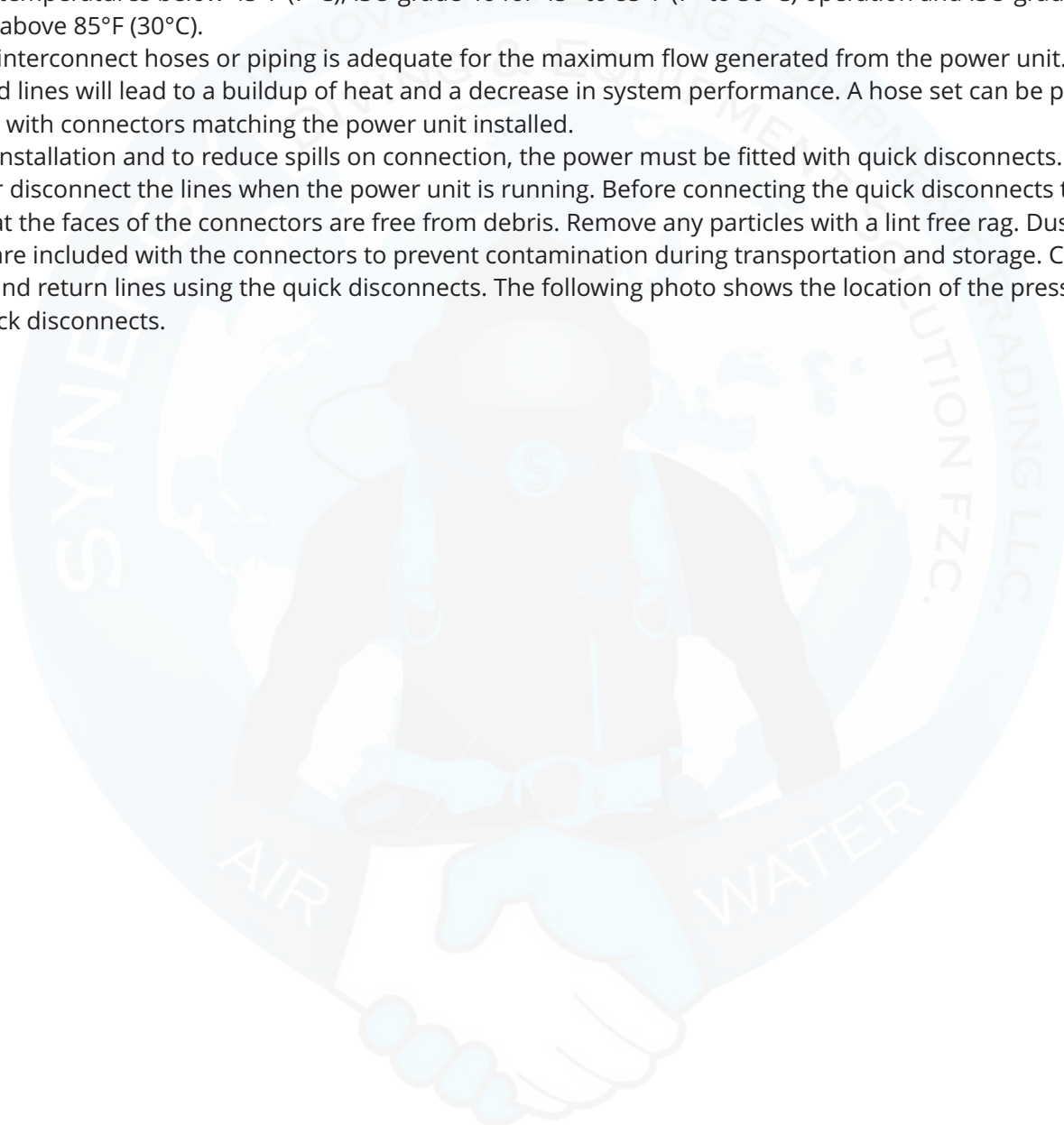

SYNERGY DIESEL ENGINE DRIVEN HYDRAULIC POWER PACK

HYDRAULIC CIRCUIT

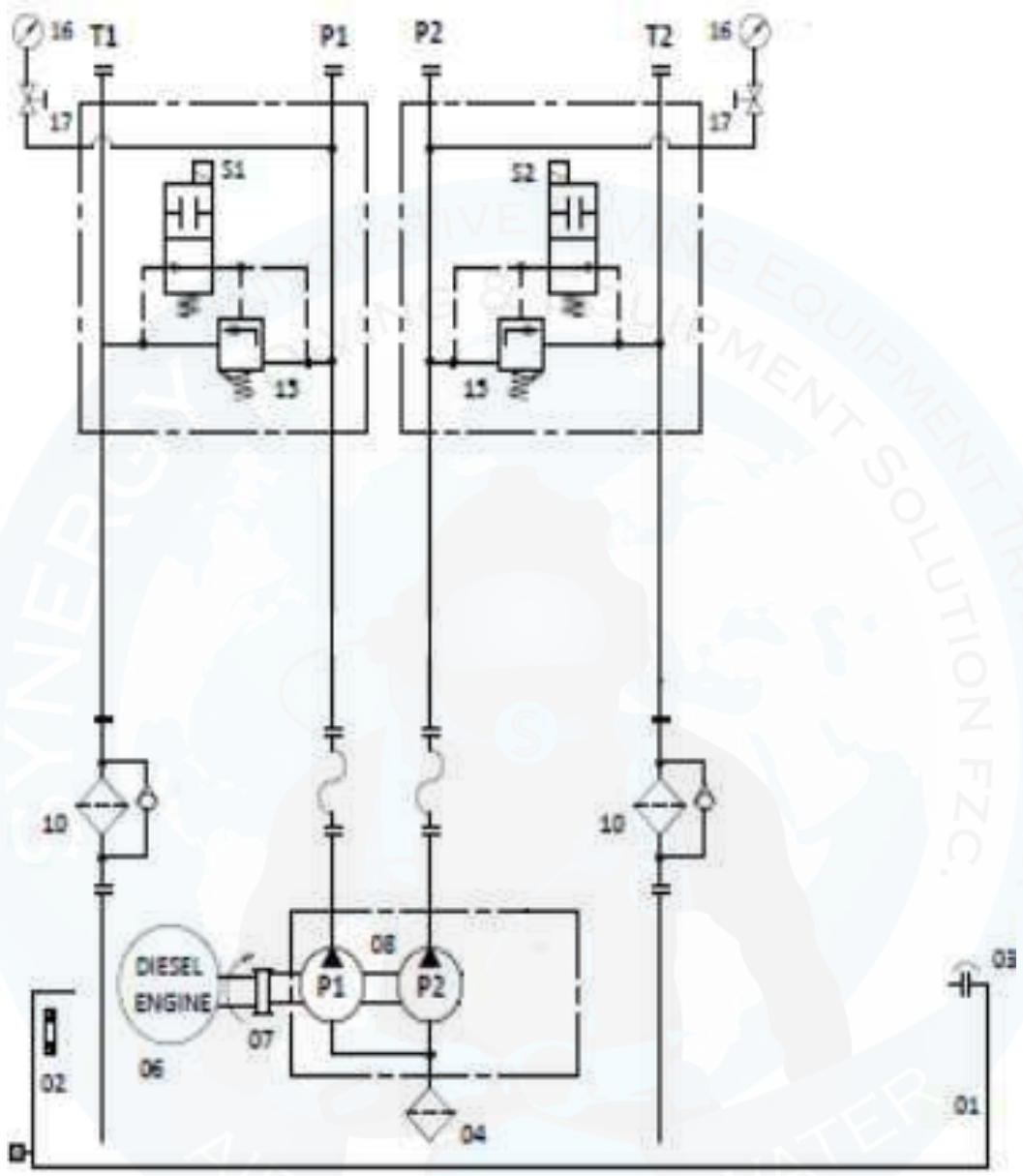

BOM FOR DIESEL TOOL POWER PACK			
SR. NO.	DISCRIPTION		MAKE
1	OIL TANK 200 LITRES	1	SVOE
2	OIL LEVEL GAUGE LG 10	1	ARE
3	FILLER COME BREATHER FSB 25	2	HYDROLINE
4	SUCTION STRAINER 2" BSP	1	HYDROLINE
6	DIESEL ENGINE 52 HP EE483	1	VECV
7	COUPLING FBC 2A	1	FANNER /SVOE
8	TANDEM PUMP VANE TYPE VTXB2-B08-B08	1	VELJAN
10	RETURN LINE FILTER RF -RB -23 -11/4"	2	UFI
15	RELIEF VALVE BSG -06-2B3B-D12	2	YUKEN
16	PRESSURE GAUGE 2 1/2" 280 BAR	2	HITECH
17	GAUGE ISOLATOR 1/4" M X F	2	ARE

SYNERGY DIESEL ENGINE DRIVEN HYDRAULIC POWER PACK

Components

The following sections will explain the major components in the hydraulic system to help the user familiarize themselves with the operation of the power unit. Examine the hydraulic schematic in conjunction with the text below. The assembly drawings will also help identify the physical locations of the components.

Hydraulic Pump

In the schematic, the hydraulic pump is referenced by item Sr. no. 8. The pump is a fixed displacement Tandem Vane pump with two sections, which is connected to the engine using a pump adapter and pump coupling. The pump flow can be adjusted by setting the engine speed RPM. The pump maximum pressure rating is 210 Bar and maximum speed is 2500RPM.

Relief Valve

These valve item Sr.No. 15 & 16 limits the maximum pressure on the circuit as mentioned in the system's safety feature section and Operation Mode selection. These are Pilot operated relief valves.

Unloading Valve

This valve is for unloading the relief valve pilot circuit. The valve is spring loaded and is supposed to unload the circuit if the engine stops or the pressure is almost 0 Bar. Once the engine is started and running and pressure is required to be loaded in the hydraulic system unloading valve. The relief valve will be loaded at the set pressure.

Suction Strainer

The suction strainer is mounted inside the reservoir. The strainer filters the hydraulic fluid going to the pump inlet.

Return Filter

Before fluid returns the reservoir, it passes through the return filters (item Sr. No. 10 & 11).

SYNERGY DIESEL ENGINE DRIVEN HYDRAULIC POWER PACK

Operation

The DHPU is a simple unit that provides pressure and flow for an open center hydraulic Tools. Closed center valves have the pressure port blocked in the neutral position. Heat builds up in the system quickly as the full flow of the system is dumped over the system relief since the flow cannot return to tank through the valve.

The prime mover for the hydraulic pump is the diesel engine. The engine rotates the pump shaft at the speed selected and the torque output is dictated by the load on the pump. This model has two fixed displacement Vane pumps coupled to the engine. The Vane pump has two sections and provides hydraulic power to either 1 or 2 the open centered circuit hydraulic tools .

The following sequences assume the necessary installation steps have been completed, and the unit is ready for start up.

Both pumps ie. Pump1 and 2 are 24.9 cc/rev (the individual pumps @1500RPM will give a flow of 37.4 LPM and 45LPM@1800 approximately

Two Tools mode with flow up to 25-45 LPM on each tool.

In this mode connect the pressure line to P#1 and P#2 and Return line 1 & 2 connection on return line filter respectively. Once the Engine is started load the power pack by switching on PUMP 1 and PUMP 2 switch as required. Set the pressure of the relief valve by shutting Off the Pressure line valve or closing the pressure line on both circuits respectively. The relief valve should be set with the pressure line closed only.

Ideally the engine should operate at 1500 RPM and that will give a flow of 37.4 LPM. The flow can be increased or decreased by varying the engine RPM.

The flow should be adjusted to optimum flow (limited to Maximum flow) Refer to Tool specifications that is being used but both pumps flow will be the same. The pressures can be individually set on each pump. Maximum operating pressure for this mode is 140 Bar /2000 PSI

In this operating mode when **only a single pump** is being used the pump pressure can be increased to 210 Bar/3000 PSI

Once the Engine is started load the power pack by switching on load valve. Set the pressure of the relief valve by shutting Off the Pressure line valve or closing the pressure line. The relief valve should be set with the pressure line closed only. Ideally the engine should operate at 1500 RPM and that will give a flow of 37.4 LPM. The flow can be increased or decreased by varying the engine RPM.

The flow should be adjusted to optimum flow (limited to Maximum flow) Refer to TOOL specifications that is being used . Maximum operating pressure for this mode is 140 Bar/2000 PSI .



DO NOT SET THE RELIEF VALVE HIGHER THAN THE POWER UNIT DESIGN PRESSURE OR THE ALLOWABLE PRESSURE TO THE COMPONENTS.

SYNERGY DIESEL ENGINE DRIVEN HYDRAULIC POWER PACK

Diesel Engine :

(Read Engine Operation Manual before operating the Engine).

Start Up

- Ensure that the installation section has been followed. Review engine operation and DSEE 100 panel manuals also prior to operation.
- Ensure that the pumps are in unloaded condition ie. The push to load valves on the hydraulic circuit relief valves for both the pumps are pulled out (although they bare spring loaded and come out automatically).
- To start the power unit, insert the key. Turn the key to the ON position. DO NOT switch off the power when the engine is running .
- Observe the engine speed, oil temperature and oil pressure on the display panel .
- The engine speed will be approximately 1500 RPM. Can be set /adjusted from (1000 to 1800 RPM) depending on the optimum flow required.

Safety Features

The power unit is equipped with several safety features, which are explored in more detail in the following sections.

Engine Silencer

The exhaust from the engine is routed through a silencer (muffler) to reduce the engine noise

Engine Spark Arrestor

After the silencer, the exhaust is routed through a spark arrestor. The spark arrestor, as seen below, uses centrifugal force to separate solids from exhaust gas. The manufacturer recommends inspecting and cleaning out the spark arrestor every 1000 operating hours or three times per season, whichever time period is less. The inspection should include a visual check for holes, cracks or metal corrosion. If any of the above conditions are found, then replace the spark arrestor. Also, ensure the mounting clamp is securely tightened.



DO NOT TOUCH THE EXHAUST SYSTEM COMPONENTS DURING OPERATION OF THE POWER UNIT AS IT HEATS UP TO DAMAGING TEMPERATURES. THIS HEAT IS RETAINED EVEN AFTER THE POWER UNIT IS TURNED OFF. VERIFY THE UNIT IS COOL BEFORE WORKING AROUND THE EXHAUST SYSTEM.

Over Speed Shutdown

If the Engine over speeds during a runaway condition , then the unit will automatically shut down when the speed exceeds the factory setting of 2400 RPM. The engine RPM should be Adjusted accordingly before proceeding with further operation. The Engine RPM is displayed on the control panel.

Emergency Stop & Manual Shutdown

The unit has an emergency stop switch(electrical) for shutdown. In case of the failure of the Emergency stop switch. Pulling and holding the lever of the STOP SOLENOID manually, detailed in the photo. The engine should not be started again until the fault is rectified .

SYNERGY DIESEL ENGINE DRIVEN HYDRAULIC POWER PACK

LOW OIL PRESSURE, HIGH COOLENT TEMPERATURE AND HIGH ENGINE OIL TEMPERATURE SHUT DOWN

The Engine is set to shut down if the oil pressure gets too low or if the engine oil temperature gets too high. The DSE E100 control panel gets these inputs through the engine sensors.

System Relief Valve

The system hydraulic pressure relief valve (Sr. No. 15&16 on the hydraulic schematic) is shown in the following photo. This valve limits the maximum pressure from the power unit hydraulic pump. It is factory set to relieve at 2000 PSI. To adjust the valve setting, loosen the jam nut on the cartridge valve stem. Turn the screw clockwise to increase the pressure setting and counter clockwise to reduce the setting. Lock the jam nut back down after adjusting the valve setting. The relief valve should be set with the pressure line valve closed quick coupling disconnected.

SAFETY INSTRUCTIONS

OPERATOR SAFETY

Follow the guidelines for safe operation of the equipment and avoid personal injury & hazard.

READ THE OPERATING MANUAL

Before you begin to operate the machine, make sure that you understand all steps and operating instructions of this manual.

INSPECT MACHINE AND ACCESSORIES.

Before starting the machine, look for loose bolts or nuts, leaking lubricant, rusted components, and any other physical conditions that may affect operation. Properly maintaining the machine can greatly reduce the chances of injury.

ALWAYS READ PLACARDS AND LABELS.

Make sure all placards, labels, and stickers are clearly legible and in good condition.

SECURE LOOSE CLOTHING AND JEWELRY.

Secure or remove loose-fitting clothing and jewelry, and securely bind long hair, to prevent them from getting caught in moving parts of the machine.

KEEP CLEAR OF MOVING PARTS.

Keep hands, arms and fingers clear of all rotating or moving parts. Always turn machine off before doing any adjustments or service.

KEEP WORK AREA CLEAR.

Keep all clutter and non essential materials out of the work area.

CHECK OIL & COOLENT LEVELS.

Don't start the power pack / engine unless engine oil level, coolant level and hydraulic oil level are checked and maintained within the permissible limit

Shutdown

- The proper way to stop the engine is to press the stop switch on the control panel. Do NOT turn OFF the Power switch.
- Verify that all operations that the power unit is driving are complete. Do not shutdown while equipment is working.
- Do not stop the engine when it is running at full load. Instead, allow the engine to cool down by letting it at idle speed for some time.
- In case of Emergency press the "EMERGENCY STOP" switch.

SYNERGY DIESEL ENGINE DRIVEN HYDRAULIC POWER PACK

Storage

Follow the steps below when removing the power unit from operation.

- Stop the diesel engine.
- Disconnect the pressure and return lines from the power unit and from the tong. Install the dust plugs and caps onto the exposed quick disconnects. Coil the hydraulic lines and place them into the storage basket on the lift frame.
- Move the power unit to its storage location.
- Clean and remove all debris from the power unit. Afterwards, inspect the unit for any damage. Address all problems identified.
- Perform any required routine maintenance on the power unit.

Maintenance

It is important to maintain the power unit in a condition that will provide continued safe operation. The following sections highlight items that need to be addressed over the life of the unit.

Before Each Job

1. Fill up the diesel fuel tank. If the engine has been run until the tank is empty, then bleed the air out of the fuel system.
2. Inspect the unit visually and look for signs of damage or leaks. Check all components (hydraulic and mechanical). Ensure all hydraulic hoses, including the interconnects, are free of damage.
3. Check the fluid level of the hydraulic reservoir.
4. Clean the engine air intake pre-cleaner.
5. Inspect the engine air intake air cleaner. Clean if required. Frequency of cleaning is dictated by the amount of the dust in the air when operating.
6. Check the engine motor oil level.
7. Set the system relief pressure to the required level for the job. 8. Drain water accumulation from the bottom of the reservoir /hydraulic oil tank (after settles).

Each 500 Hour Interval

1. Inspect the fan belt for damage. Replace if worn.
2. Replace the hydraulic return filter elements.
3. Change the engine motor oil and replace the oil filter.

Each 1000 Hour Interval

1. Replace the hydraulic oil in the reservoir. When the tank is empty, clean the interior with a lint free cloth to remove any debris deposited in the bottom. Also, clean or replace the suction strainers if contaminated.
2. Clean the fuel strainer on the engine.
3. Replace the fuel filter on the engine.

Each 1 Month Interval

1. Clean the spark arrestor on the engine.

Each 3 Month Interval

1. Verify the function of the automatic over speed shutdown. It may be necessary to adjust the maximum speed set screw to allow the engine to increase its speed. All settings must be returned to the correct position after the test.
2. Ensure the fan belt safety switch functions properly. Do not put hands into the fan belt area while the engine is running.

Hoses

Replace the hoses within appropriate intervals regardless of the condition. Every five years is the usual hose manufacturer time frame.

SYNERGY DIESEL ENGINE DRIVEN HYDRAULIC POWER PACK

Contact us

 29th Street, Amman Road, Behind Al Huraiz Est. For Industry,
Al Qusais, Industrial Area – 1,
Dubai, United Arab Emirates

 Tel : 009714 2580533 

 Fax : 042516664 

 UAE : 00971505648178 

 UK : 00447951966260 

 Website : www.synergyequipment.com

 Email : ram@synergyequipment.com

 For Sale : info@synergyequipment.com

